

Advances in Modeling Ruminant Nutrient Utilization

Ermias Kebreab

Associate Professor and Canada Research Chair,
University of Manitoba, Winnipeg, Canada

Symposium Presentation to Peruvian Society of Animal Science, Lima, Peru



Introduction

Ruminants account for a third of meat and almost all of the global milk production

Intensive research around the world

Data generated at a rapidly increasing rate

Quantitative approaches

- Increase understanding further

- Integrate various aspects

Statistical analysis and mathematical models

Introduction

From manuscripts published in *J. Anim. Sci.*

No 'modeling' papers were found before 1970

3.2% '70s, 17% '80s, 31.5% 90's

616 papers (almost 50%) published after 2000

Mathematical spectrum

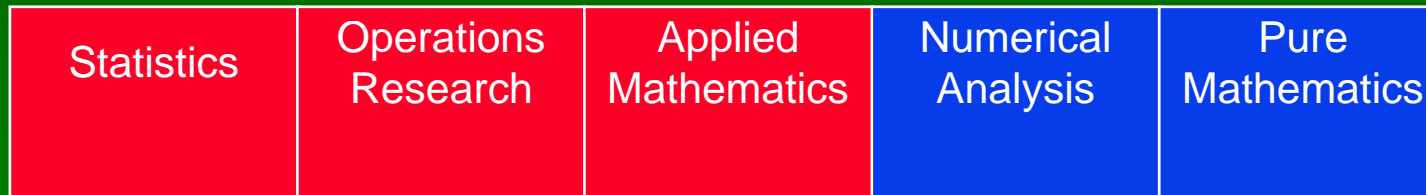

← Empirical Modelling → ← Mechanistic Modelling →

Objective

Summarize research advances made through the use of mathematical methods

understand the underlying concepts of nutrient utilization in ruminants at various levels of organization

Energy, protein (N), mineral (P), lactic acidosis, whole animal and farm models

Modeling Energy Utilization

Dietary CHO → hexoses & pentoses → VFA

95% VFA are $\xrightarrow{\text{-----}}$ acetate, propionate & $\xrightarrow{\text{-----}}$ butyrate

Fermentation stoichiometry must be known

Murphy et al. (1982) derived coefficients

Prediction not very accurate – inadequate representation of stoichiometry

Bannink et al. (2006) used meta-analysis

Modeling VFA in the rumen

Statistical approaches have limited power

- No consideration of microbial population

- Not sensitive to fermentation conditions

France & Dijkstra (2005) developed single or three pool scheme (tracer-based)

Current models still unsatisfactory

Further development should include protozoal contribution

Modeling VFA in the Rumen

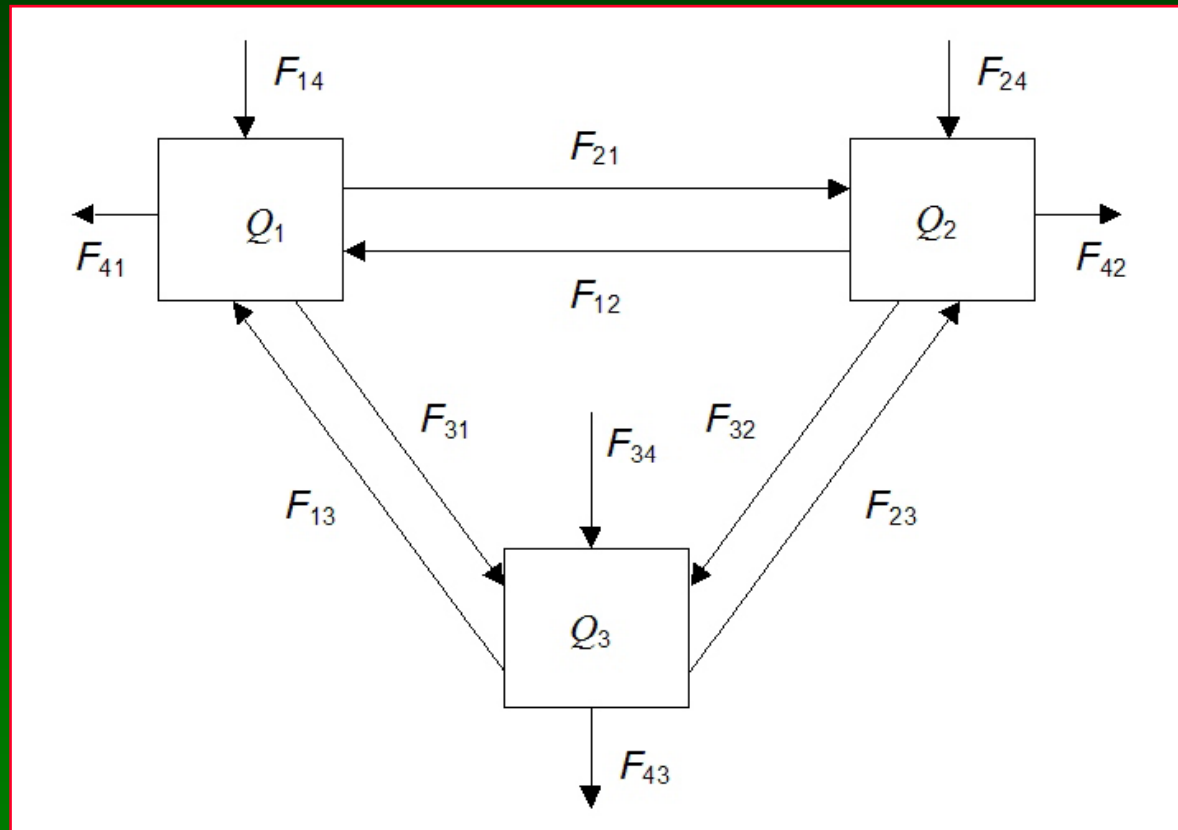

France and Dijkstra
2005. *Quantitative
Aspects of Ruminant
Digestion*, 157

Three-pool model for VFA production in the rumen showing pools and fluxes of tracee. 1=Acetate, 2=Propionate, 3=Butyrate

Modeling Methanogenesis

Methane is loss of productivity (up to 12% GE)

GHG and 21 X potent than CO₂

Lipogenic:glucogenic VFA is important

Measurement requires complex and often expensive equipment

Current estimates based on IPCC models

Methane emission models can be empirical or mechanistic

Modeling Methanogenesis

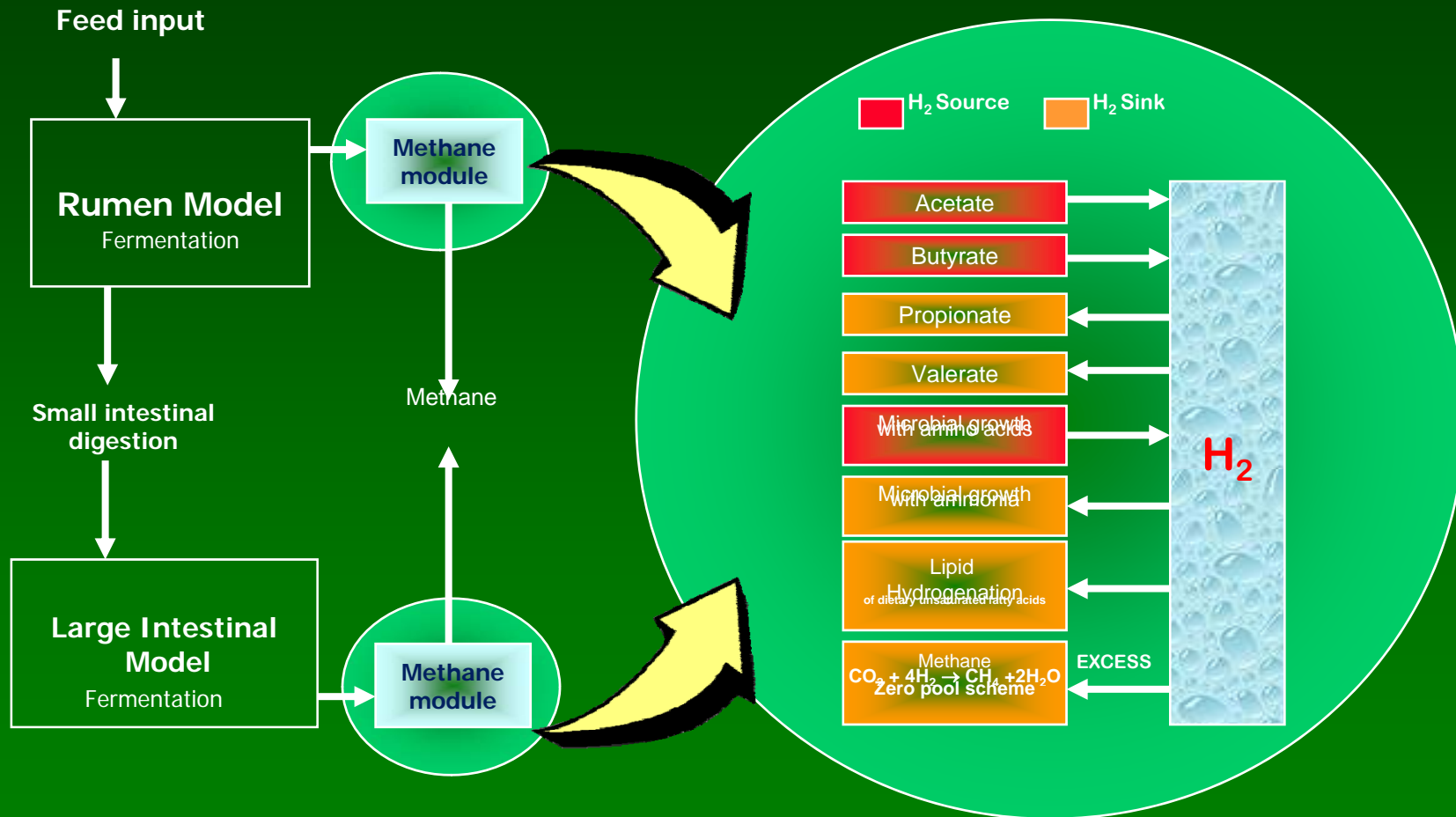

Modeling Methanogenesis

Methane Model.pdf - Adobe Acrobat Professional

File Edit View Document Comments Forms Tools Advanced Window Help

Create PDF Combine Files Export Start Meeting Secure Sign Forms Review & Comment

2 / 13 150%

Model for estimating enteric methane emissions from United States dairy and feedlot cattle¹

E. Kebreab,*² K. A. Johnson,† S. L. Archibeque,‡ D. Pape,§ and T. Wirth#

*National Centre for Livestock and Environment, Department of Animal Science, University of Manitoba, Winnipeg, Manitoba R3T 2N2, Canada; †Washington State University, Department of Animal Science, Pullman 99164; ‡Colorado State University, Department of Animal Science, Fort Collins 80523; §ICF International, Washington, DC 20006; and #Environmental Protection Agency, Washington, DC 20460

ABSTRACT: Methane production from enteric fermentation in cattle is one of the major sources of anthropogenic greenhouse gas emission in the United States and worldwide. National estimates of methane emissions rely on mathematical models such as the one recommended by the Intergovernmental Panel for Climate Change (IPCC). Models used for prediction of methane emissions from cattle range from empirical to mechanistic with varying input requirements. Two empirical and 2 mechanistic models (COWPOLL and MOLLY) were evaluated for their prediction ability using individual cattle measurements. Model selection was based on mean square prediction error (MSPE) served values, and no significant mean ($P = 0.74$) or linear bias ($P = 0.11$) was detected when residuals were plotted against predicted values. A fixed methane conversion factor (Y_m) might be an easier alternative to diet-dependent variable Y_m . Based on the results, the 2 mechanistic models were used to simulate methane emissions from representative US diets and were compared with the IPCC model. The average Y_m in dairy cows was 5.63% of GE (range 3.78 to 7.43%) compared with 6.5% \pm 1% recommended by IPCC. In feedlot cattle, the average Y_m was 3.88% (range 3.36 to 4.56%) compared with 3% \pm 1% recommended by IPCC. Based on our simulations, using IPCC values can result in

Efficiency of Energy Utilization

Traditionally NE and ME systems are used

Key parameters were by linear regression

Meta-analysis and non-linear methods

used to study efficiency (Kebreab et al., 2003)

Efficiency ME intake for milk, body gain

0.55, 0.83 vs 0.64, 0.75 (NE) 0.62, 0.60 (ME)
(MJ/kg^{0.75}/d)

Efficiency tissue for milk, maintenance

0.66, 0.59 vs 0.82, 0.51 (NE) 0.84, 0.49 (ME)

Efficiency of Energy Utilization

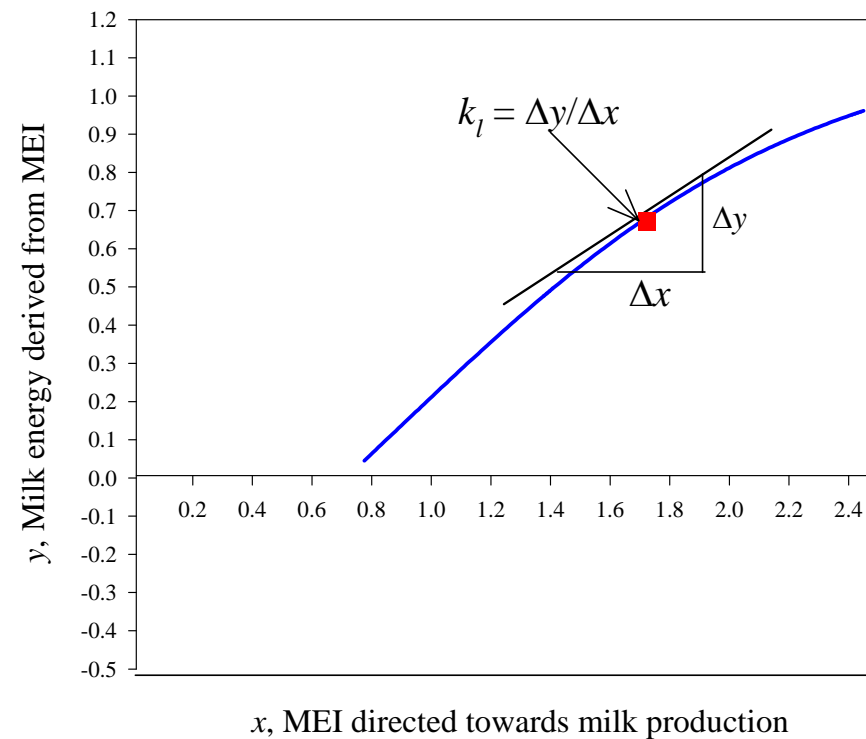

Modeling Protein (N) Utilization

Overall efficiency of dietary N

13 - 31%

Theoretically 40 – 45%

Empirical and Mechanistic

Kebreab et al. (2001)

72% of dietary N is excreted
N intake and Urine N have
exponential correlation

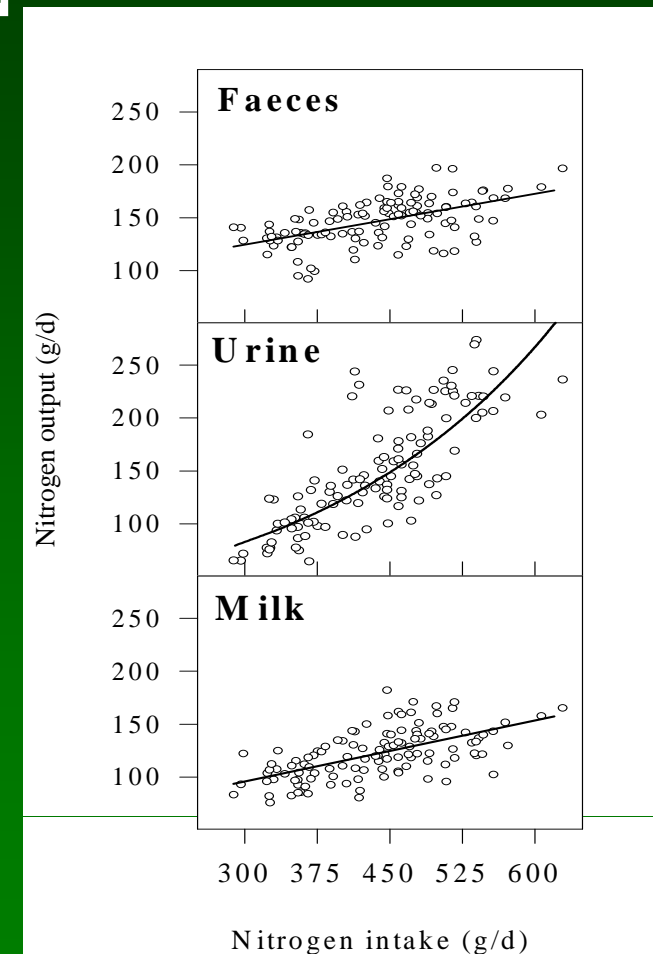

Modeling Protein (N) Utilization

N utilization affected by
Dietary N concentration
Microbial community
Urea recycling etc

Based on differential
equations

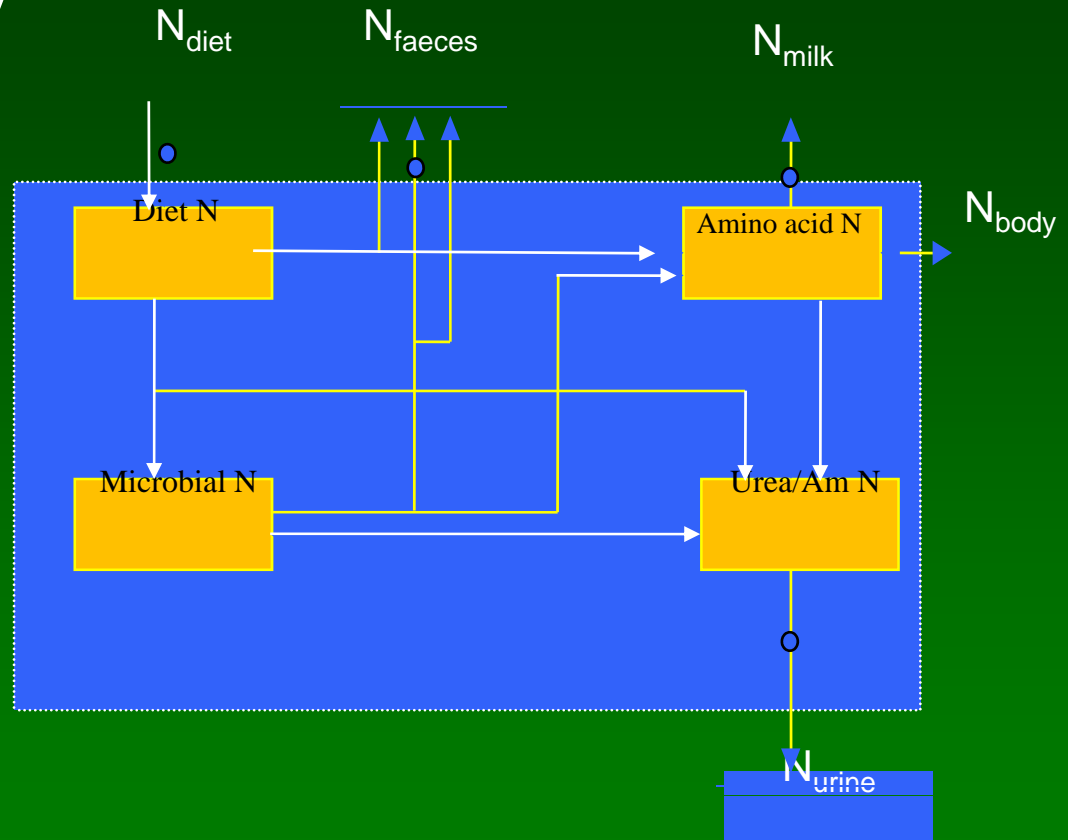

Modeling Protein (N) Utilization

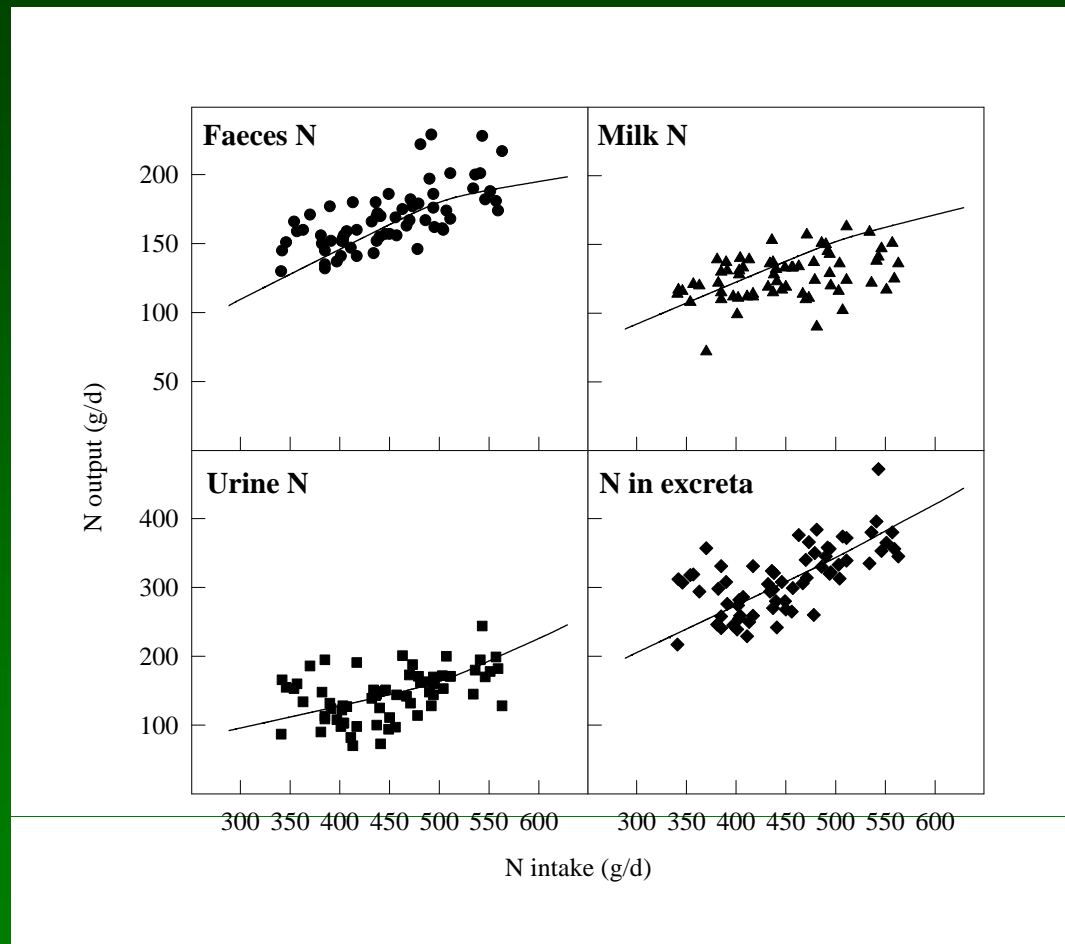

Modeling Phosphorus Utilization

Dairy cows use <40% of dietary P intake

Excess P mostly excreted in feces

Current recommendations (20 kg/d DMI)

74 g/d (AFRC, 1993)

64 - 84 g/d (NRC, 2001)

Models of P utilization include:

Statistical

Kinetic and

Dynamic

Kinetic P model

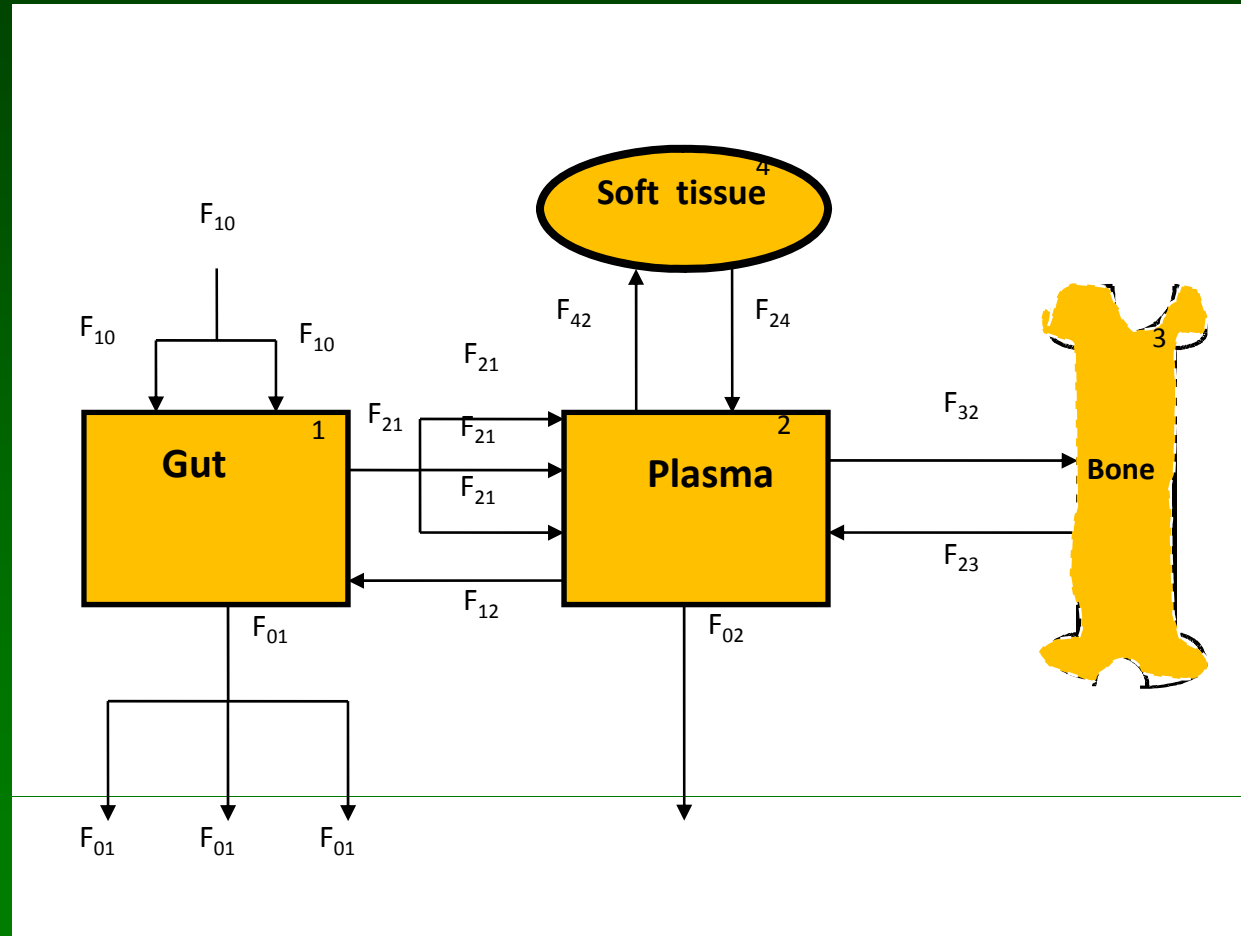

Mechanistic P model

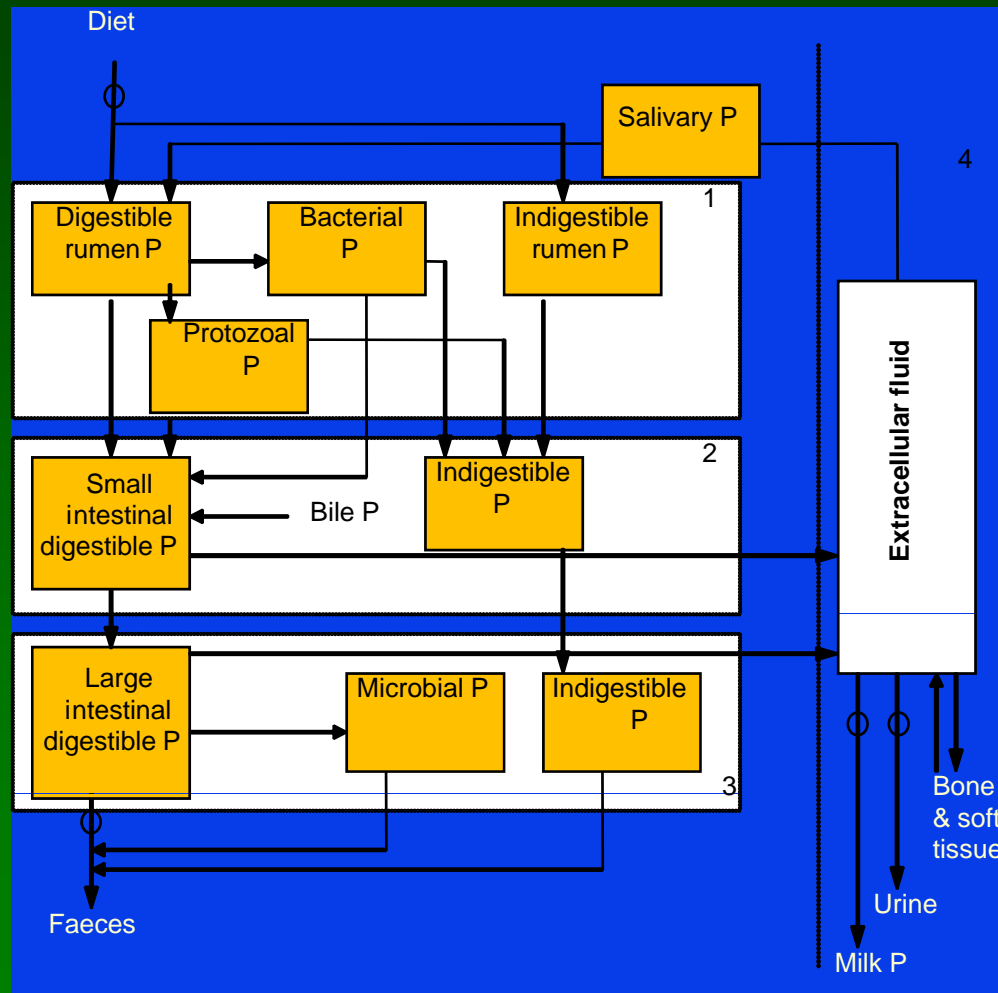

Kebreab and Vitti. 2005.
Quantitative Aspects of Ruminant Digestion, 469

Mechanistic P model

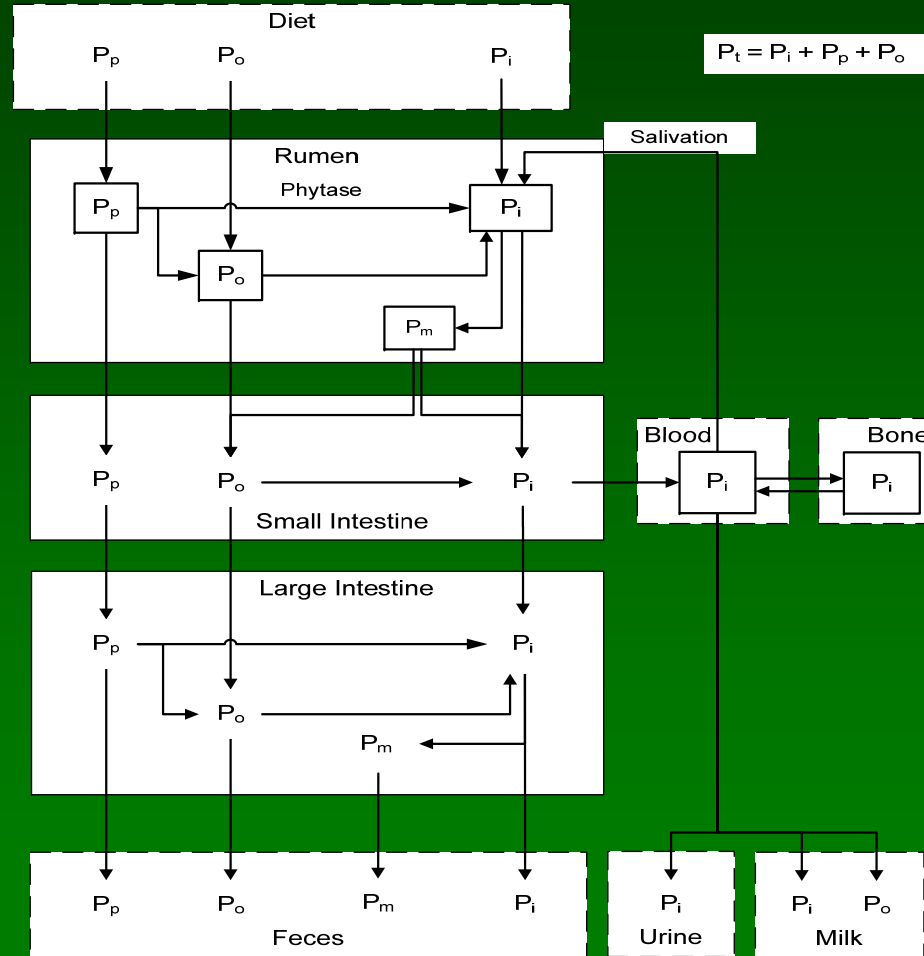

Modeling Lactic Acidosis

~~Accumulation of lactate in rumen~~

Diets rich in rapidly fermentable CHO

Starch

Water Soluble Carbohydrate

(organic acids – e.g. lactate in grass silage)

Clinical or Subclinical

Health problems (liver abscesses, parakeratosis)

Production losses

Welfare concerns

Environmental impact?

Modeling Lactic Acidosis

Various approaches have been used

Meta-analysis using growth curves

Relating rumen pH with rumen temperature

Mechanistic approach using extant rumen model

Meta-analysis – Lactic Acidosis

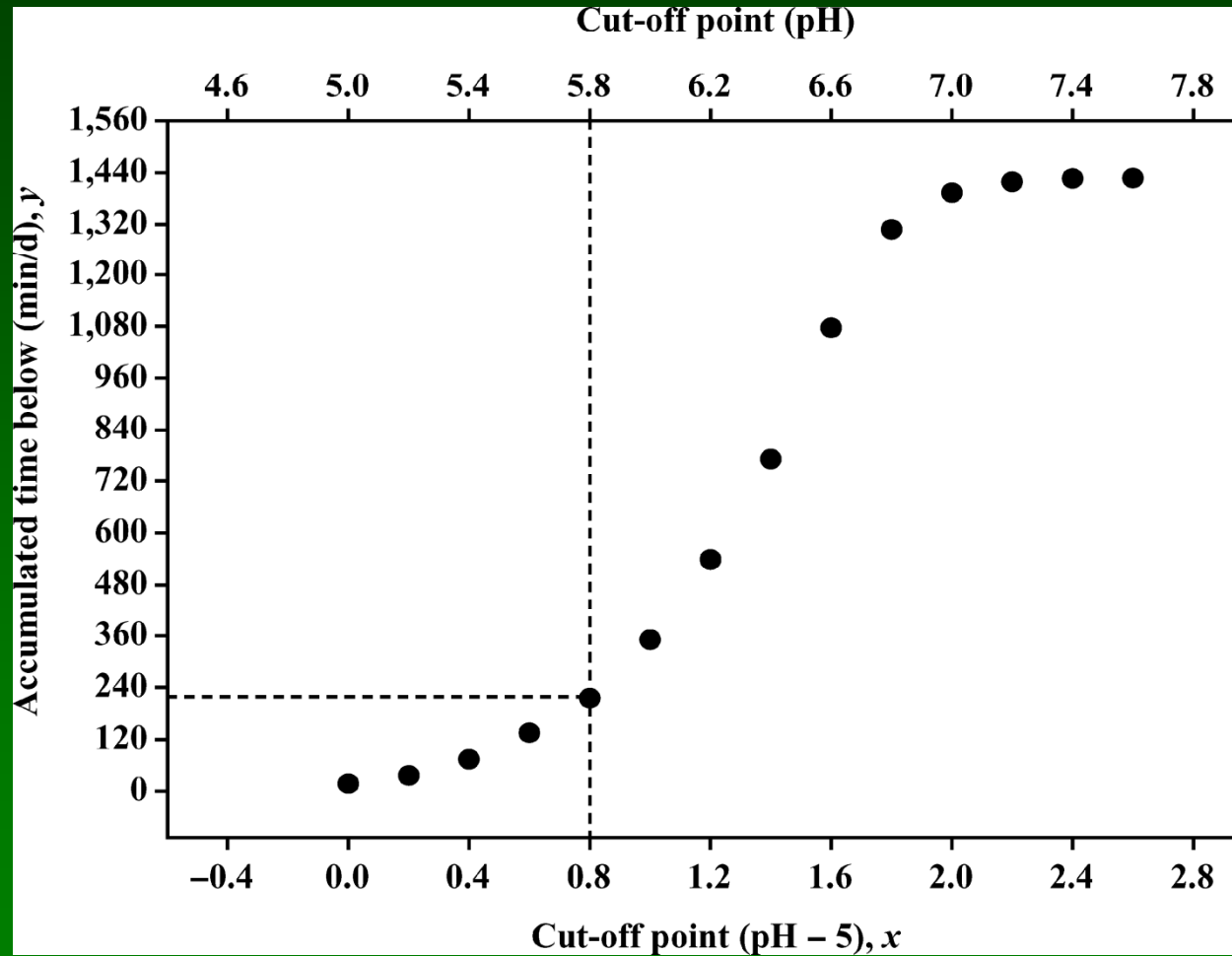

Alzahal, Kebreab et al. 2007. *J. Dairy Sci.* 90: 3777

Meta-analysis – Lactic Acidosis

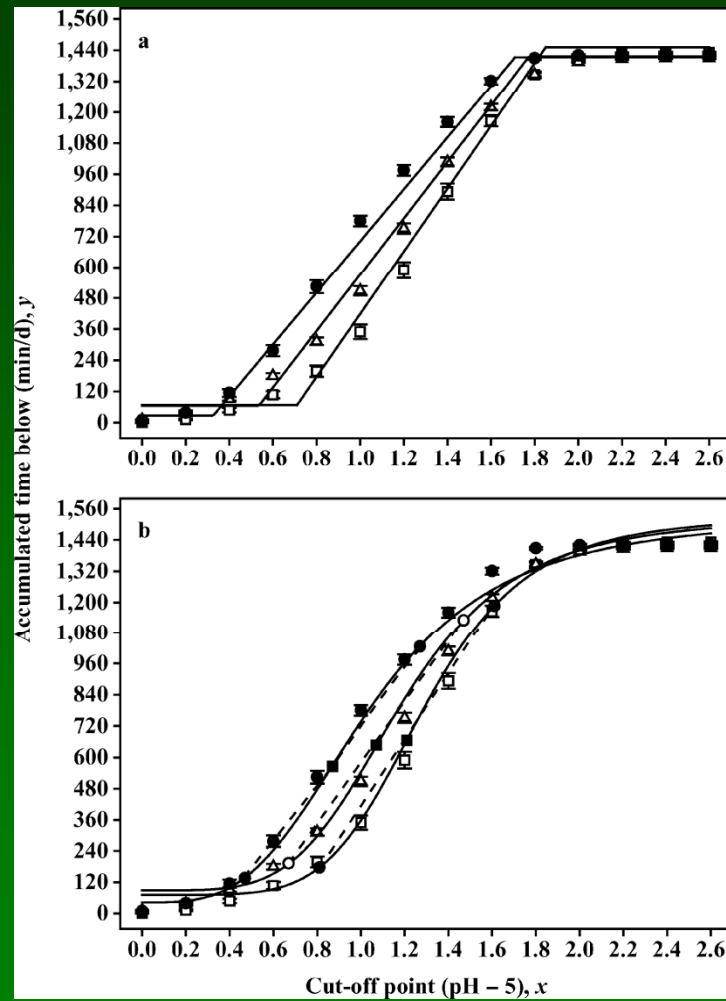

Alzahal, Kebreab et al. 2007. *J. Dairy Sci.* 90: 3777

Mechanistic Model – Lactic Acidosis

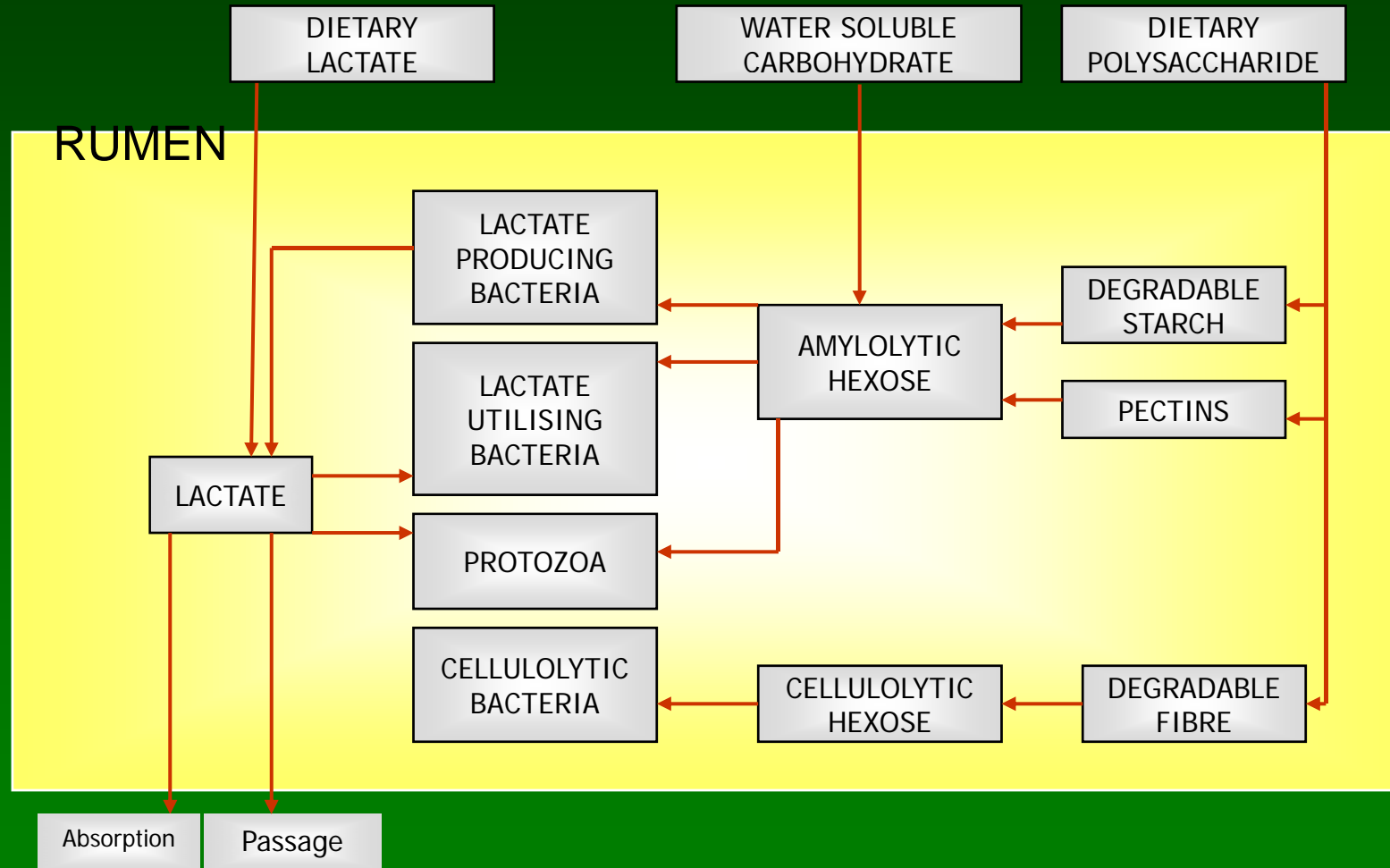

Mechanistic Model – Lactic Acidosis

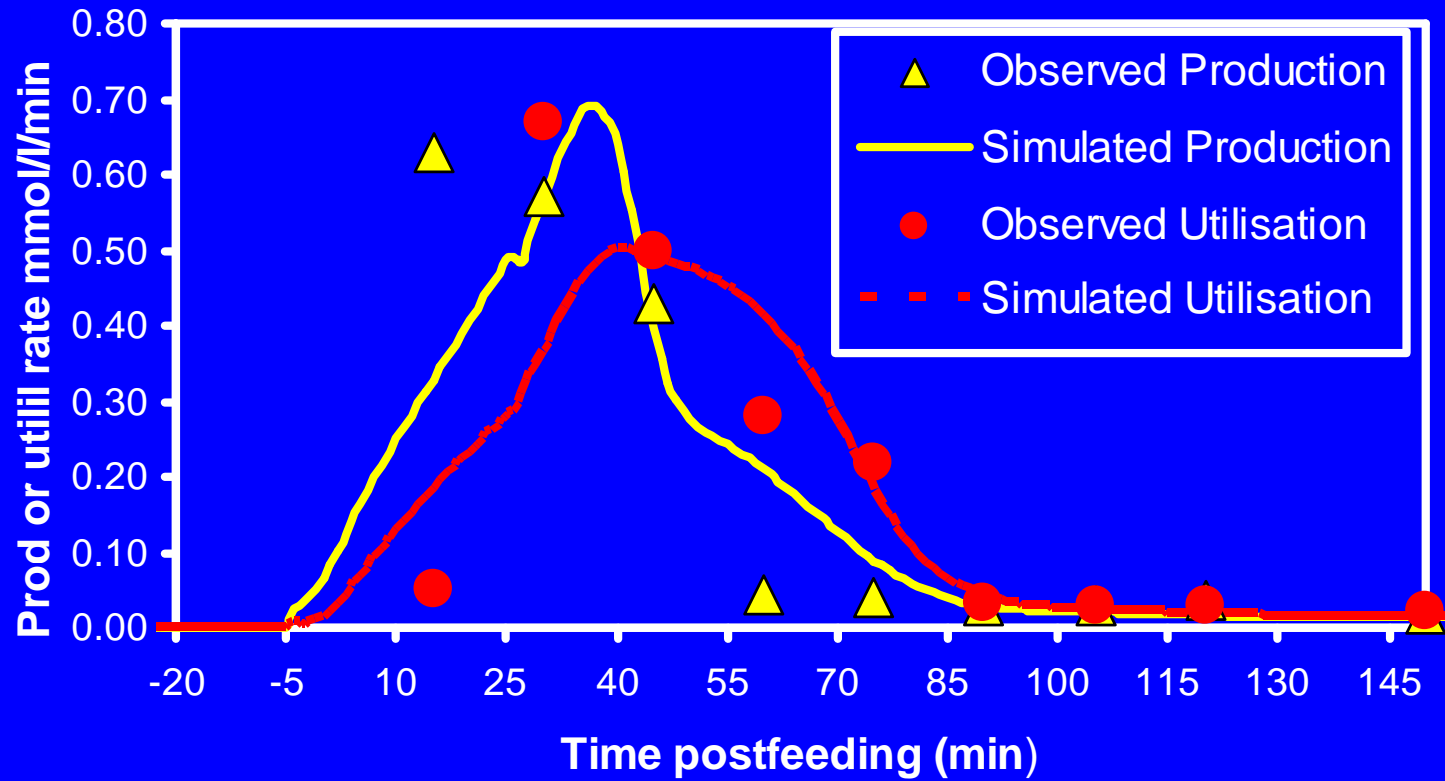

Nutrient Utilization - Animal & Farm Level

Integrated model of nutrient utilization

Addition of N, P and methanogenesis to extant rumen model and extension to whole animal level (Kebreab et al. 2004)

Nutrient utilization model for tropical cattle

Sugarcane based (Brazil and India)

Elephant grass based (Brazil)

LP models for Mexican small-scale dairy farms

Mechanistic Model – Animal Level

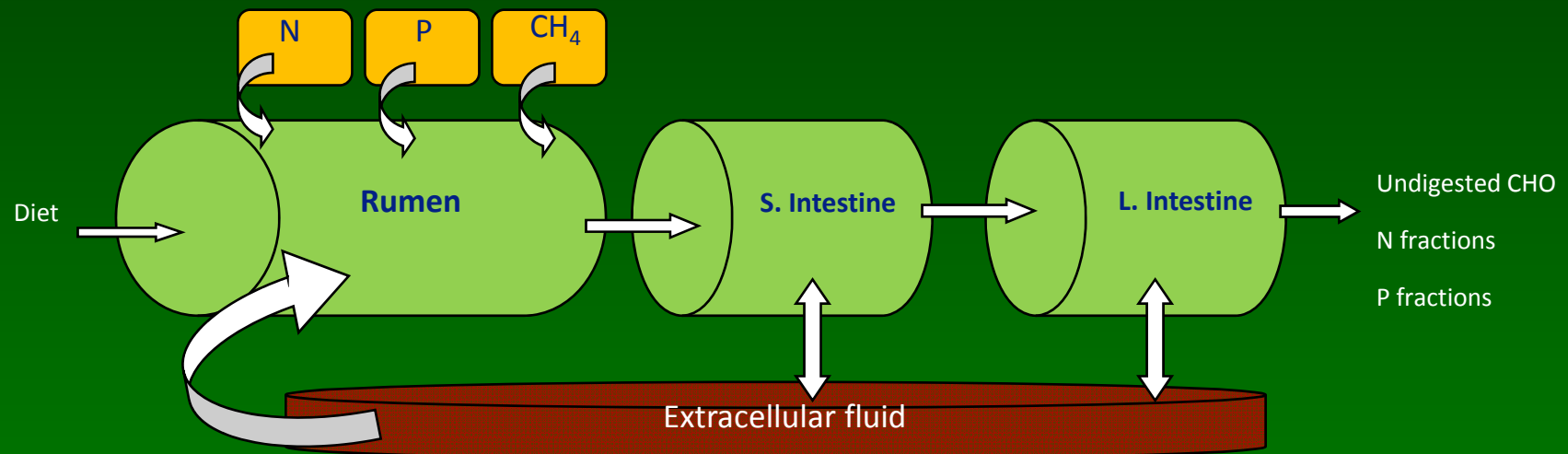

Kebreab et al. 2004. *Anim Feed Sci. Technol.* 112: 131

Mechanistic Model – GUI

The screenshot shows the 'Poll Cow - 2' software interface. The 'Results' menu is open, with 'Pollution summary' selected. The 'Pollution summary' window is displayed, showing the following data:

Display options

- Point during simulation: 21
- Precision (dec. places): 2
- Time (days): 20.00
- Results at end of simulation:

Nitrogen Balance (g/day)

- N Intake: 450.00
- Purine N: 25.33
- Urine N: 145.78
- Faecal N: 146.77
- Total N in excreta: 292.55

Phosphorus Balance (g/day)

- P Intake: 92.00
- Faecal P: 61.63
- Urinary P: 6.86
- Total P in excreta: 68.49

Methane output

	Rumen	L. Intestine	Total
mol/day	28.02	1.88	29.90
MJ/day	24.72	1.66	26.38
Litres/day	673.67	45.16	718.83
g/day	449.72	30.17	479.89

N and P in milk (g/day)

- Milk N: 113.52
- Milk P: 17.80

Pollution Indices (Excretion/milk)

- Nitrogen: 2.58 (5 green bars)
- Phosphorus: 3.85 (10 red bars)
- Methane: 23.99 (5 green bars)

Viewing Pollution outflow summary

INS CAPS NUM 18/11/20 16:22

Mechanistic Model – Tropical Animal

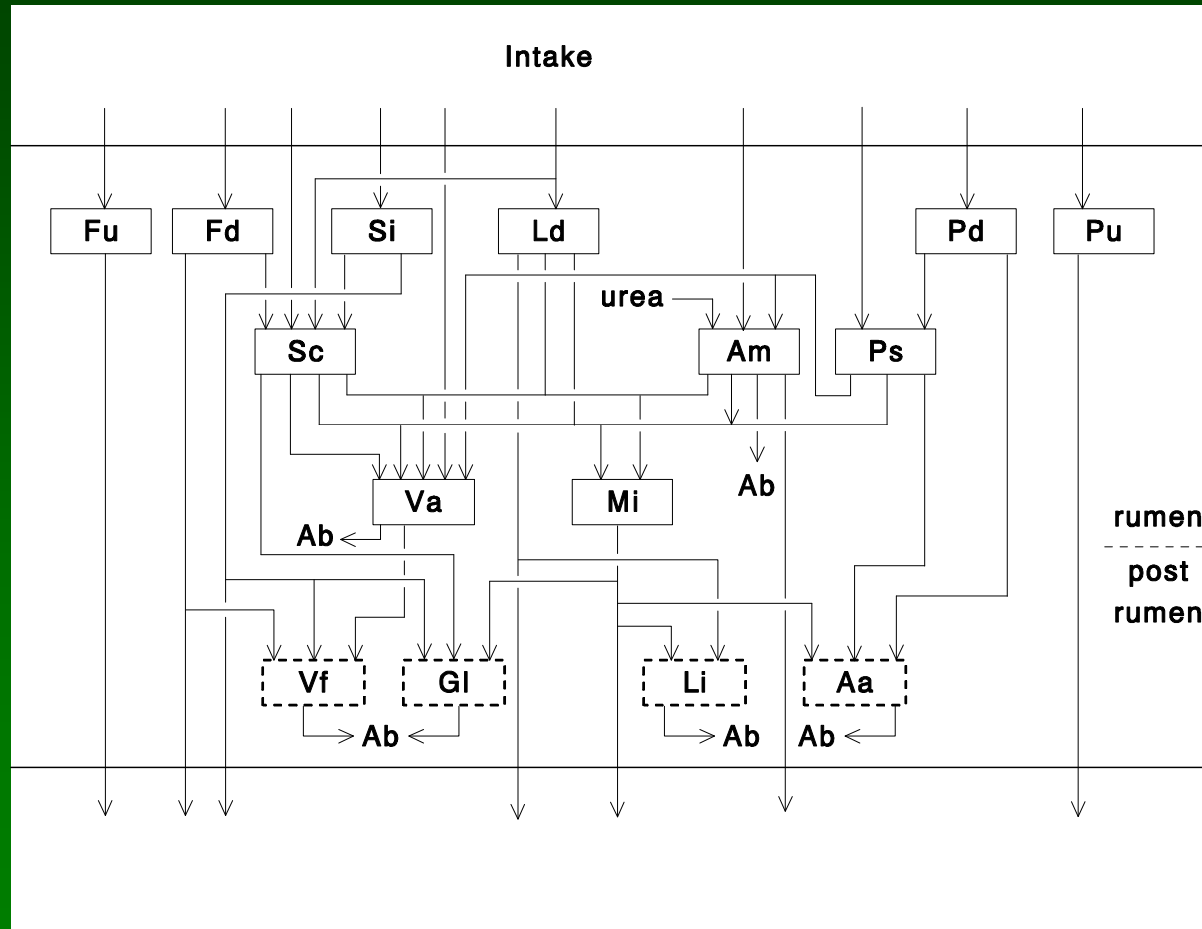

Kebreab et al. 2001. *Trop. Anim. Health Prod.* 33:127-139

Mechanistic Model – Farm Level

Compromise and goal programming

Summary of objective functions below:

Objective	Function	Description of variables
1) Maximize ME for milk production	$\sum_{j=1}^4 \left(\sum_{k=1}^9 ME_k y_{jk} - \sum_{i=1}^4 NLE_i x_{ij} \right)$	p_j = milk price in quarter j (M\$/kg).
2) Maximize margin over feed cost	$\sum_{j=1}^4 \left(\sum_{i=1}^4 MY_i p_j x_{ij} - \sum_{k=1}^9 c_{ik} y_{jk} \right)$	
3) Maximize MP for milk production	$\sum_{j=1}^4 \left(\sum_{k=1}^9 MP_k y_{jk} - \sum_{i=1}^4 NLE_i x_{ij} \right)$	
4) Minimize purchased feeds	$\sum_{j=1}^4 \sum_k c_{jk} y_{jk}$	k summed over purchased feeds

Future Research Direction

More integration of tissue-organ-animal models and upscaling to farm level

Move towards modeling discontinuous feeding and its effect on fermentation etc.

Nutrient based feed evaluation models instead of factorial approach (NRC, AFRC)

Better graphical user interface to models for general use

Thank you

Email:

kebreabe@cc.umanitoba.ca

